

All Rights Reserved

Materials and specifications are subject to change without notice. Featured machines in photos may include additional equipment. See your XCMG dealer for available options.



Hydraulic Excavators
XE160E



XCMG European Sales & Services GmbH

Add: Europark Fichtenhain B 4, 47807 Krefeld, Deutschland

Tel: +49 (0) 2151 8209 351
Fax: +49 (0) 21 51-82 09-499
E-mail: Europe@xcmg.com

XUZHOU CONSTRUCTION MACHINERY GROUP IMP. & EXP. CO., LTD

Add:NO.1, Tuolanshan Road, Xuzhou Economic Developing Zone,
Jiangsu,China 221004

Tel: +86 (0) 516 8773 9228
Fax: +86 (0) 516 8773 9230
E-mail: Europe@xcmg.com

www.xcmg.com

Rated Power: 90 kW
Operating Weight: 15.7 t
Standard Bucket Capacity: 0.65 m³





INTRODUCTION OF XCMG

Founded in 1943, XCMG is a multinational corporation with the most comprehensive range of competitive, influential products in the construction machinery industry. Our business covers eight key areas: construction machinery, heavy trucks, mining machinery, sanitation machinery, machinery components, construction, finance, and the ICT industry.

XCMG has established a global R&D system with a total of six centers across China, the US, Germany, Brazil and India, with China national technology center at its core. In addition to a number of manufacturing bases across China, the US, Germany, the Netherlands, Poland, Austria, Brazil, India, and Uzbekistan, we possess two complete machine brands (XCMG, Schwing), and several component brands including FT, AMCA, and Wika. It is the strength of this global R&D system and manufacturing operations that has made XCMG the industry-leading global construction equipment manufacturer that it is today.

For more than 30 years, XCMG has been sowing the seeds of overseas development as the No. 1 exporter in China's construction machinery industry. Today, we have 42 branches and offices, 315 distributors, 526 contractors in 188 countries and regions worldwide.

XCMG IN EUROPE

Since its inception in 2012, in these years of quick development in Europe, XCMG has gradually established a completed system including R&D development, local distribution network, supply chain management and an integrated customer services center.

Nowadays, with 4 branches, XCMG has 178 multinational employees in Europe, of which more than 50% are R&D engineers:

ERC: XCMG European Research Center GmbH

EPC: XCMG European Purchasing Center GmbH

ESS: XCMG European Sales and Services GmbH

Our local professional R&D team and cutting-edge innovation platform guarantee that our products are carefully crafted to the smallest detail according to diverse needs of European customers.



XCMG XE160E builds further on its reputation from the previous series based on the quality, reliability and durability. The enhancements deliver the best in class fuel efficiency while not compromising on power reducing emissions and consumption, while increasing productivity.

If you are looking to get your work done with a durable brand you can trust XCMG and look no further than our XE160E

► RELIABILITY

Even under the harshest conditions, XCMG has made its aim to build long-life products. XCMG has already a long relationship with the best component suppliers in the world. Cummins engines, Kawasaki KPM hydraulic pumps, main control valve and swing motor, and high quality travel motors guarantee you the best performance. Oversized cylinders in combination with long-life reinforced pins, polymer shims and bushings ensure best performance with unchanged durability.

► PRODUCTIVITY AND EFFICIENCY

Strong and unmatched bucket and arm digging forces give XE160E the ability to fulfil the most challenging tasks on your jobsite with excellent productivity and efficiency.

► SAFETY SOLUTIONS

A rear camera and large side mirrors, powerful LED lighting, anti-slip steps and platforms. Guard rails for safe access to the upper structure. The ROPS (Roll Over Protective Structure) and the OPG (Operator Protective Guard) cabin ensures the operators' safety.

► VERSATILITY

Multiple boom and arm sizes together with special configurations are available to efficiently carry out any task your business requires.

► EASY-TO-USE ATTACHMENTS

Programmable auxiliary single line is provided to support your hydraulic attachments like hammer and many more.

► COMFORTABILITY

To ensure operator comfort, we offer a spacious cab with low noise and vibration levels and excellent all-round visibility.

Mechanical suspension seat and air conditioning with climate control as standard.

► CONTROLLABILITY

8 work and 3 power modes, with a user-friendly 8" TFT LCD color monitor.

► STRONG POWER

The Cummins B4.5 stage V/Tier 4 Final engine is exceptionally powerful - with high torque at low revs. This makes that maximum flow is already available at low rpms with a fuel-efficient engine regime.

► ADVANCED FILTRATION

Easily accessible highly efficient filters and cleaners that remove all contamination from your jobsite protect your investment in the best possible way.

► SIMPLE AND EASY MAINTENANCE

Easy access to all compartments. Maintenance data and signs are directly available from monitor.

► UNDERCARRIAGE DURABILITY

The CAE designed X-shape undercarriage enables even weight distribution, increases stability and durability, and prevents damage from rocks and debris.



► Power without compromise

The XE160E makes handling your task efficient and comfortable.

The optimized Kawasaki-KPM hydraulic system makes sure that all that engine power is used in the best possible way by delivering accurate maximum pumping in a smooth way.

All that power has reliably increased the digging power, the lifting capacities, and the traction force.

Greater fuel efficiency means you can keep costs down and reduce environmental impacts.



POWER MATCH TECHNOLOGY

The XE160E is equipped with a Cummins B4.5 engine. Famous for its excellent fuel efficiency, reliability and long service intervals it combines exceptional power output and high torque at low revs.

The engine is fitted with a high-pressure common-rail fuel system combined with cooled exhaust gas recirculation(EGR) and a Cummins VGT TM turbocharger, which increases the density of the air and enables the engine to produce more power.

Selective Catalytic Reduction (SCR) technology in combination with a Diesel Oxidation Catalyst (DOC) - ensures compliance with Stage IV regulations.

There is no need for a DPF. If the engine is the heart of the excavator, the XICS (XCMG Intelligent Control System) is its brain – providing a perfectly synchronized communication link between the engine's ECU (Electronic Control Unit) and the hydraulic system. The CANBUS (Controller Area Network) system enables a constant flow of information between engine and hydraulic system, so that power is delivered exactly as needed.

FUEL ECONOMY TECHNOLOGY

- A choice between 3 power modes and 8 working modes guarantees optimum performance under all conditions.
- Electronic control of fuel consumption.
- The auto-idle function reduces the engine speed when the controls are inactive for a preselected amount of time or when the safety lever is switched off. The engine will immediately return to its original selected speed when the operator touches the controls.
- For optimum cooling,the fan speed is controlled by a viscous clutch that results in lower fan noise with better fuel efficiency.

- The XE160E cabin is designed to support increased productivity with a spacious comfortable operator environment. The pressurized cab is ISO-certified for your safety and offers a comfortable mechanical suspension seat with several storage compartments and a clear all-round view of your jobsite. The reduced noise and vibration levels with automatic air-conditioning/climate-control will make your workday more easy and comfortable.

Advanced control technology

Ergonomic, advanced and simple-to-operate joystick delivers ultra-precise and smooth control over all movements.

Air conditioning with automatic climate control

A choice from 5 different working modes to regulate the airflow and to adjust the system's air temperature maintains the optimal desired temperature. A recirculation function is also available.

DAB radio as standard

DAB radio delivers better sound quality than traditional AM/FM radio for the driver.

Storage space

The new cab has 7 storage compartments - including a hot/cool box, a storage box for magazine/papers and a cup holder.

Cab suspension

Even at the roughest applications where you are working,the cab's improved new suspension system dampens and smoothens out unwanted feedback from your jobsite.





Simple and Easy Control

Machine interfaces

All machine interfaces – including joysticks, keypad, panel, and larger LCD monitor – are ergonomically designed for optimum control and efficiency, resulting in increased productivity and workplace well being. The switches have been simplified and climate control is now integrated into the keypad for easy adjustments.

- The new multi-function 8" TFT LCD monitor displays a comprehensive range of useful technical information, allowing you to check the machine's status and settings at a glance.
- Highly sensitive and low-effort joysticks and clear convenient controls enable you to work smooth and safely with minimum effort for increased comfort and efficiency.

Intelligent Monitor

The upgraded 8" TFT monitor features a day and night display with full user access to the machine settings and maintenance data. Any abnormality is clearly displayed on the screen, allowing you to work safely and confident with an accurate overview of all conditions.

All-important data can be directly monitored from the main screen

- | | |
|-------------------------------------|--------------------------------|
| 1.Blue-tooth | 2.Energy-saving mode indicator |
| 3.Travel speed indicator | 4.Automatic idling indicator |
| 5.Power reinforcing indicator | 6.Implement mode indicator |
| 7.Power mode indicator | 8.Alarm icon prompt area |
| 9.Surveillance image | 10.Clock time |
| 11.Urea level | 12.Buzzer silence indicator |
| 13.Main interface function settings | 14.Main menu |
| 15.Coolant temperature gauge | 16.Fuel level gauge |
| 17.Fault code display | 18.Fault analysis content |
| 19.Work hour display | |

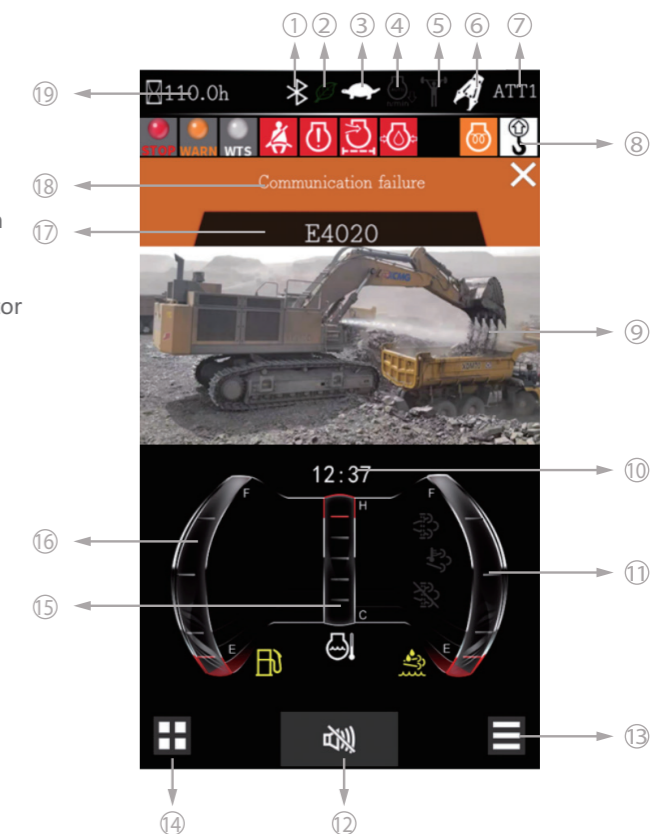

Dynamic power management

- Activating the power boost control system increases the digging force by 8.8%
- Auto-idling starts 2.5 seconds after all controls are returned to the neutral position.

8 work modes and 3 power modes

Deliver the needed power according to your specific application while minimizing fuel consumption:

- N: Normal mode
- P: Power mode
- T: Plateau mode
- B: Breaker mode
- ATT1: Hydraulic shear mode
- ATT2: Hydraulic thumb mode
- ATT3: Hydraulic rotating attachment mode
- ATT4/ATT5/ATT6/ATT7: Auxiliary mode

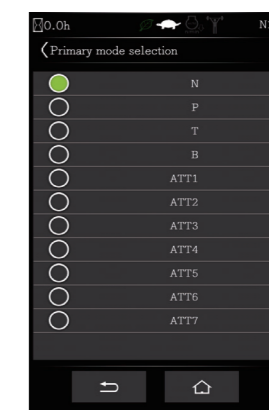

- 1 Mechanical suspension seat
- 2 Large travelling pedal
- 3 Throttle dial
- 4 Cub holder
- 5 All around AC and heating
- 6 Hydraulic joy sticks
- 7 High quality speakers
- 8 Emergency stop
- 9 Hammer control pedal
- 10 Armrest
- 11 LCD monitor

► Designed for long-term robustness and safety

XCMG has developed one of the most rigorous strength and reliability testing procedures, The XCMG E-series features durability under the most extreme conditions and is therefore one of the most popular brands in its home market.

We continually manufacture the most durable machines in order to reduce the cost of ownership. The robust upper frame, undercarriage structure, and front attachments show their real value in tough working conditions and guarantee higher productivity.

Reinforced durability of the X-chassis

The X-shaped undercarriage has a higher durability than demanded on the jobsite, as proven through numerous tests including road tests and virtual simulation.

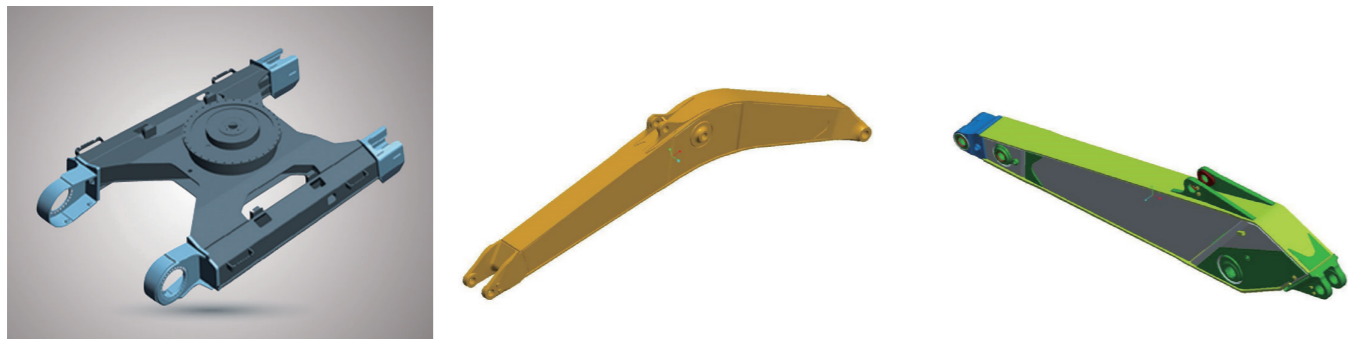

Undercarriage durability with easy maintenance

- The chain is composed of sealed, self-lubricating links for long-term performance
- Long life track tensioners and the idlers
- Heavy-duty wear resistant cast sprockets
- Durable lubricated track rollers

Strengthened boom and arm

FEA has been used to calculate the best load distribution throughout the machines structure. For better protection of the base of the arm, reinforced bars have been added. The arm structure have been strengthened for the roughest conditions.

Hi-grade (high-pressure) hoses

The E-series uses a new type of high-pressure hoses with improved heat and pressure resistance to increase the durability of the machine.

Reinforced pin, bush and polymer shim

The new series improved the lubricity of the connecting parts between the machine and attachments. Gaps with attachments are minimized by wear-resistant long-life pins, bushes, and polymer shims, supporting the highest performance with invariable durability.

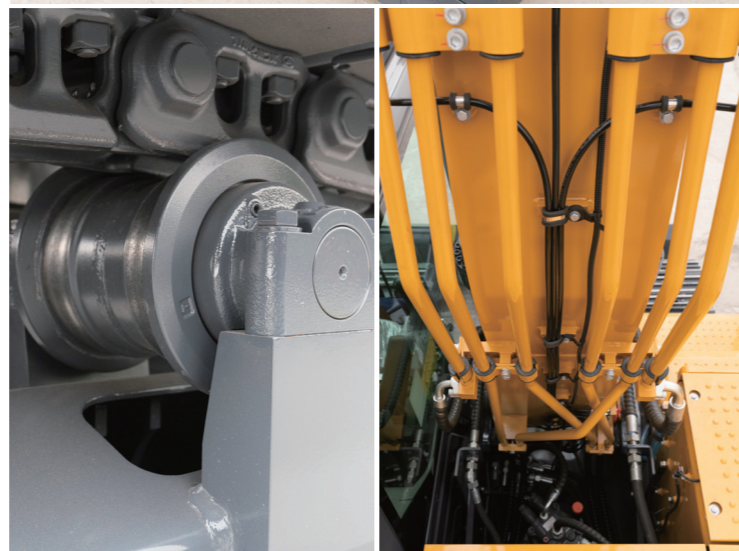
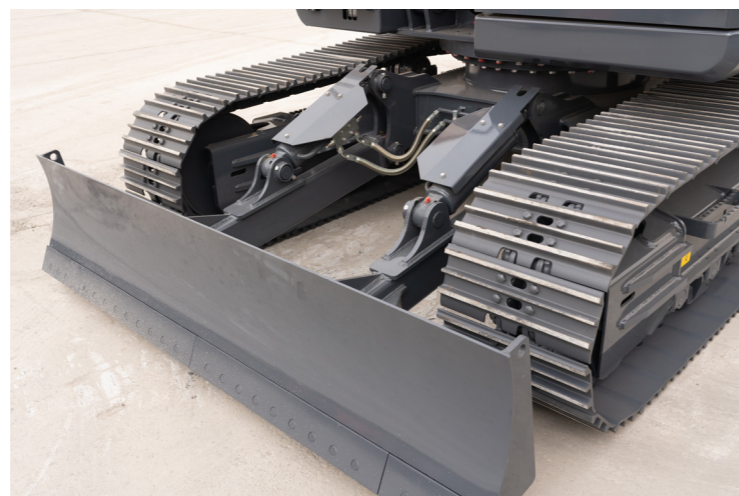

► Excellent serviceability

Our machines are designed for simple routine maintenance, while skilled XCMG technicians are available to provide extra support if needed. To get the most out of your machine, choose the package you need from a broad range of service agreements. Uptime, productivity and residual value are all maximized, making the XE160E an economical and rewarding choice.



Simple and easy maintenance

- A large guard rail is installed along with anti-slip steps and plates for safer and easier access to the upper structure
- The cab's air-conditioning filter is lockable and placed on the cab's side for easy access
- A battery cut-off switch to easily disconnect the battery for jobsite-required safety measures.
- Shut-off valves on the pre-filter piping line and the fuel tank drain piping makes servicing easier and prevents pollution from leakage.
- The engine parts can be reached easily via the top and side panels
- For extra accessibility and servicing convenience, all filters (engine oil filter, fuel pre-filter, fuel filter and hydraulic pilot filter) are located in the pump compartment.

Pre-start monitoring system

The XE 160E has a pre-start monitoring system that shows you coolant temperature, hydraulic oil temperature, engine oil pressure, fuel levels and AdBlue® level. It will also show fluid and filter intervals to keep the machine in top performing condition.

Proactive maintenance solutions

- Extended warranty: covering parts, travel, and labor
- Routine maintenance: your dealer will support you with routine service at regular intervals
- Genuine parts: manufactured and tested to ensure long lifetime of your machine.

SCR tank and easy diesel filling

The ECU (Engine Control Unit) monitors with sensors of the AdBlue® system and warns the operator for potential system malfunctions.

Fuel filler pump, an on-board pump system, lets you fill your fuel tank quickly from an external source (like a fuel drum) – the system stops automatically when the fuel tank is full or the fuel source is empty.

Centralized lubrication greasing points

To make maintenance easier.

■ Engine

Designed to deliver superior performance and fuel efficiency, the Cummins Stage V diesel engine fully meets the emissions regulations. To optimize machine performance, the engine uses high-pressure fuel injectors, a VGT™ turbocharger inter-cooler, and electronic engine controls. 4-cycle water-cooled, turbocharged, Exhaust Gas Recirculation (EGR) and \ Selective Catalytic Reduction (SCR) without a Diesel Particulate Filter (DPF).

XE160E	
Model	Cummins B4.5
No. of cylinders	4
Rated power at 2,200 rpm	
(SAE J1995)	90 kW (121 hp) at 2,200 rpm
(SAE J1349)	—
(ISO 9249)	—
Max. torque at 1,500 rpm	500 N.m
Idle (low - high)	900 - 1,100 rpm
Piston displacement	4.5 L
Bore × stroke	107mm × 124 mm
Starter	24 V × 4.8 kW
Batteries - Alternator	2 × 12 V, 100Ah - 24 V, 70 A
Air filter	*Donaldson's the latest PSD air filter and pre-filtered dust separator*

■ Undercarriage

Extremely robust construction throughout - made of high-quality, durable materials, with all welded structures designed to limit stresses.

- Lifetime lubricated track rollers, idlers and sprockets fitted with floating seals
- Track shoes made of induction-hardened alloy with triple grouser
- Heat-treated connecting pins
- Hydraulic track adjuster with shock-absorbing tension mechanism

• Number of rollers and track shoes per side

XE160E	
Upper rollers (standard shoe)	1
Lower rollers	7
Number of links and shoes per side	45
Overall track length	3,658

■ Swing mechanism

The swing mechanism uses an axial piston motor, driving a 2-stage planetary reduction gear for maximum torque bathed in oil.

- Swing bearing: single-row, shear type ball bearing with induction hardened internal gear
- Internal gear and pinion immersed in lubricant

• Swing speed & torque

XE160E	
Maximum swing speed	12 rpm
Maximum swing torque	34 kN.m

■ Drive

An independent, high-torque axial piston motor through a planetary reduction gearbox drives each track. Two levers with foot pedals guarantee smooth travel with counter-rotation on demand. The track frame protects the travel motors with hydraulically released multi-disc brakes and planetary gears.

• Swing speed & torque

XE160E	
Travel speed (low - high)	3.1-4.9 km/h
Maximum traction	127 kN
Maximum gradeability	35° / 70%

■ Hydraulic system

The XICS (XCMG Intelligent Control System) is the brain of the excavator - minimizing fuel consumption and is enabling the efficiency of the hydraulic system to be optimized for all working conditions. To harmonize the operation of the engine and the hydraulics, the XICS is connected to the engine's electronic control unit (ECU) via a data transfer link.

- The hydraulic system enables independent and combined operations -2-speed travel offers either increased torque or high travel speed
- Cross-sensing pump system and auto-deceleration system improves fuel efficiency.
- 8 work modes, 3 power modes - flow and pressure control of auxiliary hydraulic circuits from the control panel
- Computer controlled pump flow control

• Pump flow and system pressure

XE160E	
Main pumps, type	*2 × variable displacement tandem axial piston pumps*
Maximum flow	2 × 130 L/min
Pilot pump, type	Gear pump
Maximum flow	18 L/min
Relief valve settings	
Pressure up	34.3/37 MPa
Travel	34.3 MPa
Swing	25 MPa
Pilot	3.9 MPa

■ Hydraulic cylinders

High-strength steel piston rods and cylinder bodies. A shock-absorbing (cushion) mechanism fitted in all cylinders for shock-free operation and extended piston life.

Cylinders	Quantity	XE160E
Boom	2	105 × 70 × 941
Arm	1	115 × 80 × 1,120
Bucket	1	100 × 70 × 875

■ Weight (Triple grouser)

Shoe width (mm)	Operating weight (t)	Ground pressure (kPa)
500(Std.)	15,510	47
600	15,720	40
700	15,940	35
800	16,150	31

■ Fluid capacities

XE160E	
Fuel tank	250 L
Hydraulic oil tank	95 L
Engine oil	11 L

■ Cab

Note – Declared single-number noise emission values are the sum of measured values and the associated uncertainty, and they represent upper boundaries of the range of values which is likely to occur in measurements.

• Noise emission

XE160E	
Noise level LpA (ISO 6396)	72 dB(A)
Noise level LwA (ISO 6395)	101 dB(A)

■ Component weights

Item	Unit	XE150E	Remarks
Upper structure	kg	8,368	With counterweight
Lower structure assembly	kg	5,058	500 mm shoe
Front assembly	kg	2,083	Without cylinder
Counterweight	kg	2,960	Standard counterweight
Boom	mm / kg	4,600/896	Including bushing
Arm	mm / kg	2,520/457	Including bushing



Lifting Capacities

XE160E

■ Standard track width: 2,490 mm • W/o Bucket One-piece boom 4.60 m Arm 2.52 m Shoe 500 mm Counterweight 3.0 t

B	A	1.5 m		3 m		4.5 m		6 m		At Max.Reach		
		☺	☹	☺	☹	☺	☹	☺	☹	☺	☹	A
6.0 m	kg					3,263*	3,438			3,070*	2,570	5,361
4.5 m	kg					3,466*	3,377	3,272	2,155	2,979	1,958	6,347
3.0 m	kg			5,549*	5,867	4,256*	3,206	3,212	2,100	2,598	1,698	6,870
1.5 m	kg			5,076*	5,264	4,787	2,995	3,117	2,013	2,511	1,642	7,037
0.0 m	kg			7,704*	4,985	4,680	2,839	3,035	1,939	2,510	1,618	6,873
-1.5 m	kg	5,586*	5,586*	9,107	4,993	4,561	2,799	3,026	1,931	2,784	1,782	6,353
-3.0 m	kg	9,858*	9,858*	7,322*	5,021	4,570	2,806			3,552	2,245	5,371

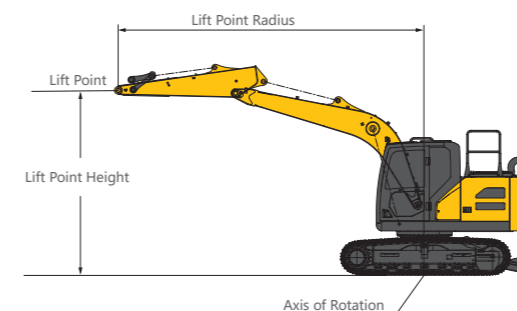

☺ : Over front
☹ : Over side or 360°

1. The lifting capacity is in accordance with ISO10567:2007.
2. All that marked with (*) refers to the lifting capacity limited by the hydraulic capacity.
3. The lifting capacity displayed should not exceed 75% of the minimum tipping amount or 87% of the hydraulic capacity.

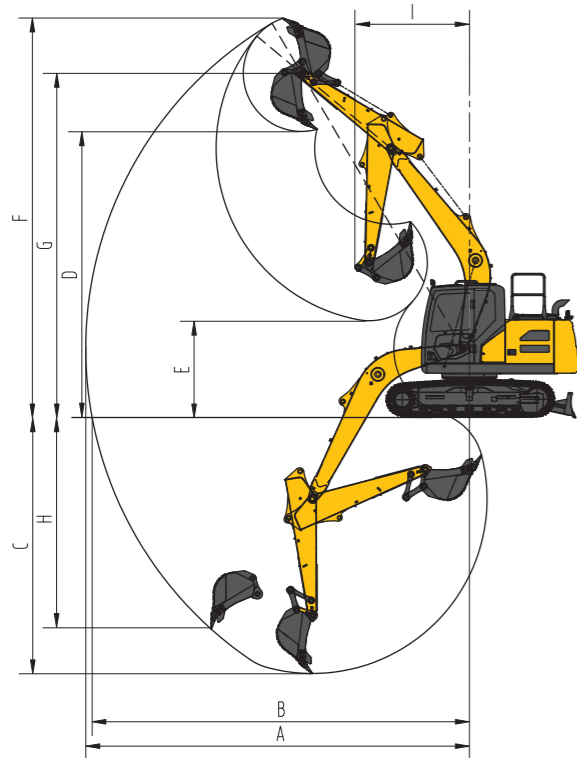

Working range

		XE160E
A	Max. digging reach	8,295 mm
B	Max. digging reach (ground)	8,155 mm
C	Max. digging depth	5,535 mm
D	Max. loading height	6,185 mm
E	loading height	2,088 mm
F	Max. digging height	8,630 mm
G	Max. bucket pin height	7,449 mm
H	Max. vertical wall depth	4,574 mm
I	Min. swing radius	2,475 mm
J	Maximum Blade depth	540 mm
K	Maximum Blade height	385 mm
L	Blade height	467 mm

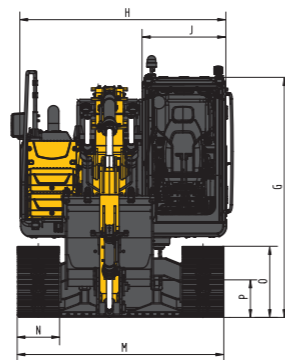
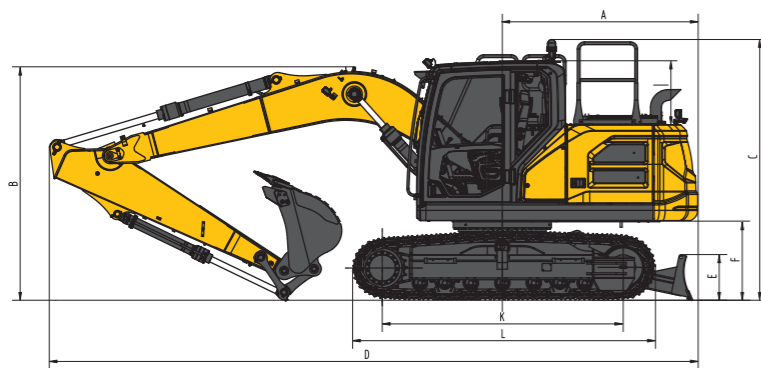
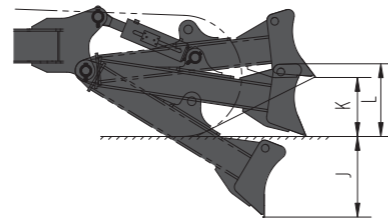

Dimensions

		XE160E
A	Tail swing radius	2,290 mm
B	Shipping height (boom)	2,852 mm
C	Shipping height (Cab)	3,133 mm
D	Shipping length	7,774 mm
E	Dozer height	467 mm
F	Counterweight clearance	940 mm
G	Height over cab	2,882 mm
H	Upper Structure width	2,490 mm
I	Cab height above house	766 mm
J	Cab width	1,020 mm
K	Tumbler distance	2,910 mm
L	Track length	3,658 mm

Dimensions

		XE160E
M	Undercarriage width	2,490 mm
N	Shoe width std	500 mm
O	Track height	836 mm
P	Ground clearance	477 mm

Digging forces

		XE160E
	Bucket digging force	107 kN
	Arm digging force	80 kN

Standard and optional equipment

Engine

AdBlue	●
Automatic preheating	●
Fuel-water separator with water level indication sensor	●
Fuel-water separator with heater [24V]	○
Axial seal air cleaner	●
Air prefilter	●
50°C high temperature ambient cooling assembly	●
Dust screen for radiator	●
Fuel marker	●
Fuel-water quick release device	●
Fuel filling pump 50L/min	●
Fuel breather valve	●
Air filter service indicator	●
Auto-idle function	●

Hydraulic system

Auxiliary hydraulic valve	●
One way hydraulic line for hammer	●
Hydraulic quick coupler lines	○
Attachemnt tilting and rotating lines	○
Hydraulic oil ISO VG 46	●
Hydraulic oil ISO VG 32	○
Hydraulic oil ISO VG 68	○
Spare valve plate	●
Gauge pressure monitoring	●

Cab & Interior

Pressurized cab	●
Mechanical suspension seat	●
Control box	●
Front windshield divided 70/30 ratio	●
Double laminated windshield and other toughened windows	●
Sliding fold-in front window	●
Bi-directional air outlet air conditioner with defroster [automatic type][pressurization function]	●
Color LCD capable of displaying warning information, filter / liquid replacement information and working hours	●
Travel control pedal with detachable manual control lever	●
Double stereo speaker	●
Cup holder	●
Coat hook	●
Floor mat	●
Retractable seat belt [51 mm [2"] wide]	●
High and low travel speed switch	●
One-key boost mode	●
Reserve switch for working aids	●
Sunlight protection, roof	●
Top sunroof	●
Windshield wiper with intermittent feature	●
File packet	●
Hot and cool box	○
Rear window emergency exit	●
Hammer for emergency escape	●

Undercarriage

2x7 bottom roller	●
2x1 top roller	●
Bottom frame traction ring	●
500 mm (20") triple grouser track shoes	●
Protective device kit: undercarriage bottom sealing plate	●
travel motor sealing plate	●
600 mm (24") triple grouser track shoes	○
Track rubber block	○

Working device

Boom 4.6 m	●
Arm 2.52 m	●
0.65 m³ reinforced bucket	●

Electronic system

Battery [2x 750 CCA]	●
70 A 24 V DC generator	●
4.8 kW starter motor	●
24 V cigarette lighter	○
12 V cigarette lighter	●
5 V USB interface	●
Engine stop switch in the cab	●
Rear-view camera	●
270° range image	○
DAB radio (FM/AM/RDS/DAB/Bluetooth/USB)	●
Travel buzzer with switch	●
Beacon lamp	●
2 LED cab-mounted front lights	●
1 LED cab-mounted rear light	●
2 LED boom-mounted lights	●
12V power interface	○
Ceiling light	●

Counterweight

3.16 t counterweight	●
----------------------	---

Lubrication system

Centralized lubrication greasing points	●
---	---

Safety

Driving door locks and cabin locks	●
Alarm horn	●
Isolation plate between engine and oil pump chamber	●
Battery circuit breaker	○
Overheat alarm	●
Safety handrails and pedals	●
Anti-skid plate/ anti-skid paste	●
Hydraulic safety locking lever	●
Right and left rear-view mirrors	○
Counterweight rear-view mirrors	●
Roll over protective structure [ROPS]	●
Operator protective guard [OPG]	●
Safety net on the front lower windshield	●

Standard: ●
Optional: ○

Some of these options may be standard in some markets. Some of these options may not be available for certain markets. Please check with your local XCMG dealer for more information about availability or to adapt your machine to your application needs.

Optimum services , XCMG Guaranteed



XCMG approved attachments



Genuine parts



Extension of warranty



Financial solutions



Maintenance contract



Telematics



Monitoring systems

Professional Integrated Complete Solutions

XCMG group has built a strong reputation based on the quality, reliability and durability of its construction machinery. What's more, XCMG has gradually established a service network to constantly provide its local integrated and highly efficient complete solutions for all users.

Full range of services ready for you

In order to respond to your needs as fast as possible, XCMG experts are on their way to your job site from one of our facilities near you. Full range of services are available in order to reduce your total cost of ownership and increase your revenue.



XCMG Global Spareparts System

Item No.	Part Name	Quantity	Unit
1	Excavator	1	PC
2	Excavator	1	PC
3	Excavator	1	PC
4	Excavator	1	PC
5	Excavator	1	PC
6	Excavator	1	PC
7	Excavator	1	PC
8	Excavator	1	PC
9	Excavator	1	PC
10	Excavator	1	PC

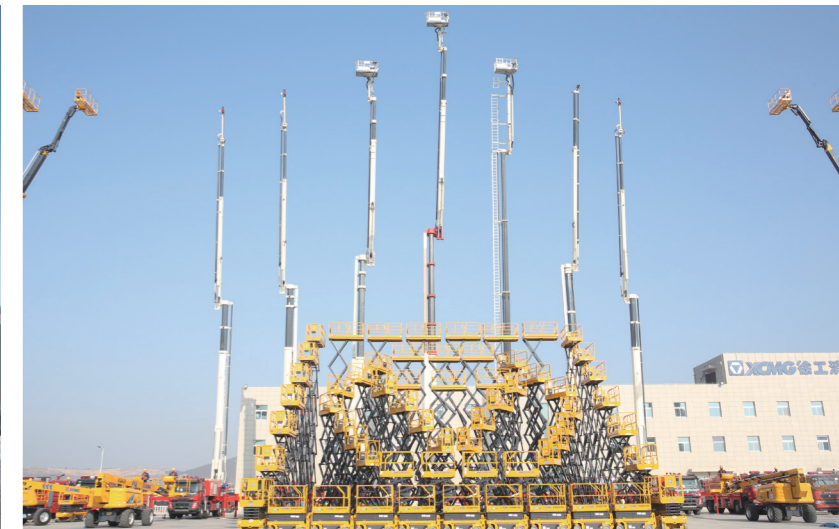

Mobile cranes



Excavators



Aerial work platforms



Wheel loaders



Road machinery

